

Microprocessor Burner Controls

RM7840 Programmers



Microprocessor-based integrated burner control for automatically fired gas, oil, coal or combination fuel single burner applications.

Provides safety, functional capability and features beyond conventional controls.

- Functions include automatic burner sequencing, flame supervision, system status indication, system or self-diagnostics and troubleshooting
- Access for external electrical voltage checks
- Application flexibility and communication interface capability through Modbus™
- Five LEDs provide sequence information
- Five function Run/Test Switch
- Interchangeable plug-in flame amplifiers
- Local or remote annunciation of RM7840 operation and fault information using the S7800 Keyboard Display Module (not included)
- Nonvolatile memory retains history files and lockout status after loss of power
- Compatible with existing Honeywell flame detectors
- SIL3 Capable in a properly designed Safety Instrumental System when using amplifiers R7847B,C; R7849B; R7851B,C; R7852B; R7861A and R7886 with their appropriate flame detectors

Dimensions in inches (millimeters)

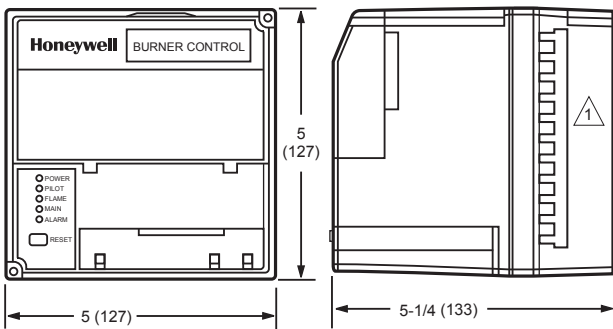

1 REMOVE ONLY FOR TERMINAL TEST ACCESS. M5003B

Early Spark Termination: Yes, 5 sec

Preignition: Yes

PrePurge: Determined by ST7800A Purge Timer Card

PostPurge: 15 sec

AirFlow Check: User selectable

Weight: 1 lb 13 oz (0.8 kg)

Approvals

Canadian Standards Association: Certified, File No. LR95329-3

Control Safety Devices: Acceptable: CSD-1

Federal Communications Commission: FCC Part 15, Class A, Emissions

Factory Mutual: Report No. OX4A5.AF

Swiss RE (formerly IRI): Acceptable

Underwriters Laboratories, Inc: Component Recognized, File No. MP268; Guide No. MCCZ.

Required Components: Q7800A,B Universal Wiring Subbases. R7847, RR7849, 7851, R7852, R7861, or R7886 Flame Signal Amplifier. ST7800A Plug-in Purge Timer Card.

Application: Programming Control

Ambient Temperature Range: -40 F to +140 F (-40 C to +60 C)

Vibration: 0.5 G environment

Frequency: 50 Hz; 60 Hz (±10%)

Pilot Type: interrupted



Product Number	Voltage	Flame Establishing Period		Second Stage Pilot Valve	Interlocks	Comments
		Main	Pilot			
RM7840E1016/U	120 Vac (+10, -15%)	10 sec or 15 sec	4 sec or 10 sec	Interrupted	Lockout	LHL-LF&HF Proven
RM7840G1014/U	120 Vac (+10, -15%)	10 sec, or 15 sec, or 30 sec, or Intermittent	4 sec or 10 sec	selectable	Running	LHL-LF Proven
RM7840L1018/U	120 Vac (+10, -15%)	10 sec or 15 sec	4 sec or 10 sec	Interrupted	Lockout	LHL-LF&HF Proven
RM7840L1026/U	120 Vac (+10, -15%)	10 sec or Intermittent	4 sec or 10 sec	Intermittent	Lockout	LHL-LF&HF Proven
RM7840M1017/U	120 Vac (+10, -15%)	10 sec or Intermittent	4 sec or 10 sec	Intermittent	Running	On/Off-LF Proven